

Model 153B Series Barge & Tanker Vents

SPECIFICATION SHEET

The Barge and Tanker Vent is used for pressure and vacuum venting of compartments on barges.

The Barge and Tanker Vent was tested by a 3rd party testing center for the opening pressures of the pressure and vacuum plunger. It was also tested for flow capacity. Each valve passed the tests within the requirements of the USCG specifications. U.S. Coast Guard Approval Numbers are as follows:

Approval Number	Figure Number
162.017/178/0	Fig. 153BSS
162.017/179/0	Fig. 153B

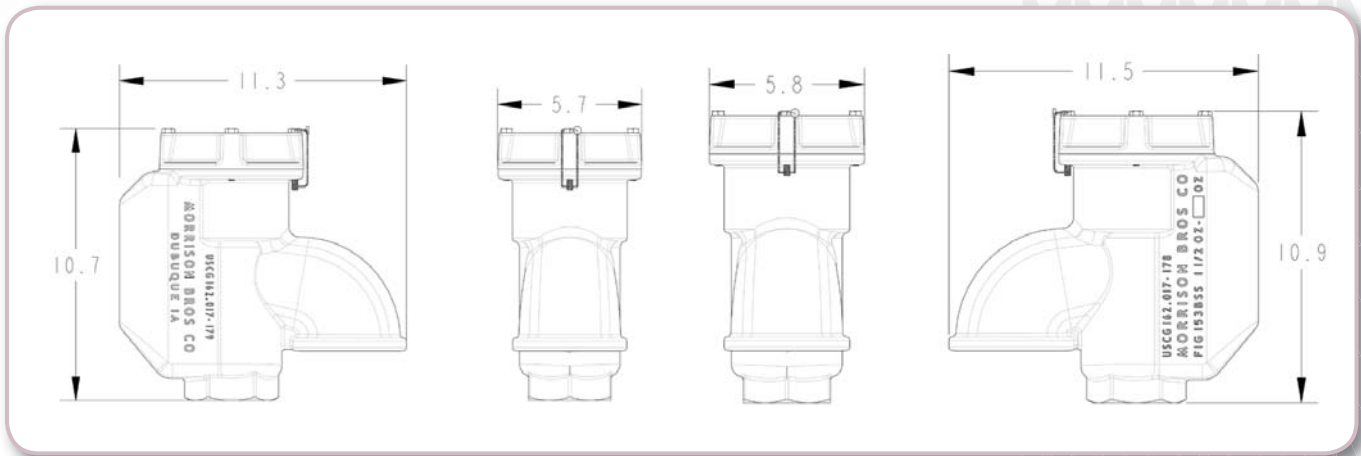

I.D. Number	A	B	C	D	Weight
153B--0100 AV	2.5"	BR	1.5	1.5	25.2 lbs
153B--0200 AV	2.5"	BR	4	1.5	25.2 lbs
153B--0300 AV	2.5"	BR	8	1.5	25.2 lbs
153B--0400 AV	2.5"	BR	16	1.5	25.2 lbs
153B--0500 AV	2.5"	BR	32	1.5	25.2 lbs
153BSS0100 AV	2.5"	SS	1.5	1.5	29 lbs
153BSS0200 AV	2.5"	SS	4	1.5	29 lbs
153BSS0300 AV	2.5"	SS	8	1.5	29 lbs
153BSS0400 AV	2.5"	SS	16	1.5	29 lbs
153BSS0500 AV	2.5"	SS	32	1.5	29 lbs

SPECIFICATION OPTIONS:

- A—Size Female NPT Threads
- B—Brass (BR), Stainless Steel (SS)
- C—Pressure (oz/sq inch)
- D—Vacuum (oz/sq inch)
- Weight—Shipping Weight

Screen is 30 Mesh

570 E. 7th Street, P.O. Box 238 | Dubuque, IA 52004-0238
t. 563.583.5701 | 800.553.4840 | f. 563.583.5028