

Kaltey Commander Tank Controller Wall Mount



Tank Controller for use with oil, waste oil, diesel fuel, antifreeze, water and other fluids with a high flash point.

- Self-regulating fluid transfer system.
- Provides automatic re-filling of monitored tank.
- Prevents costly tank overfills.
- Built in overflow monitoring-103 decibel alarm siren and flashing LED.
- Push to fill button provides instant topping off of monitored tank.
- Engineered for most single or double wall tanks with 2" NPT bung opening.
- Designed for tank depths between 24"-78" (610 mm-1981 mm).
- Requires one air powered diaphragm pump not included.
- System shuts off air to diaphragm pump and oil flow to day tank when high level sensor is tripped.
- System includes: wall mounted controller, air solenoid valve, fluid control valve, 115 volt ac adaptor, 25 ft of cabling.
- Tank depth and riser height information required at time of order.

Monitors and Alarms

MODEL NO.	DESCRIPTION	SHIPPING WEIGHT LBS (KG)
010614	Kaltey Commander Wall Mount Tank Controller	14 (6.4)

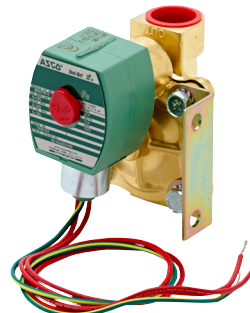



Kaltey Commander Tank Controller Wall Mount

Tank Controller for use with oil, waste oil, diesel fuel, antifreeze, water and other fluids with a high flash point.

Dimensions and System Options

Accessories

MODEL NO.	DESCRIPTION
013752	Kaltey Commander Wall Mount Tank Controller Remote Sensor

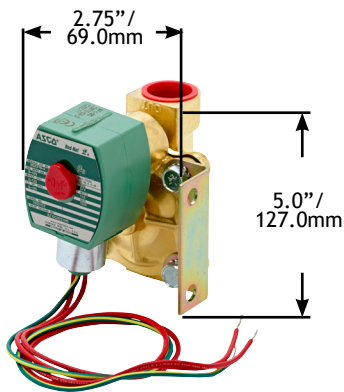
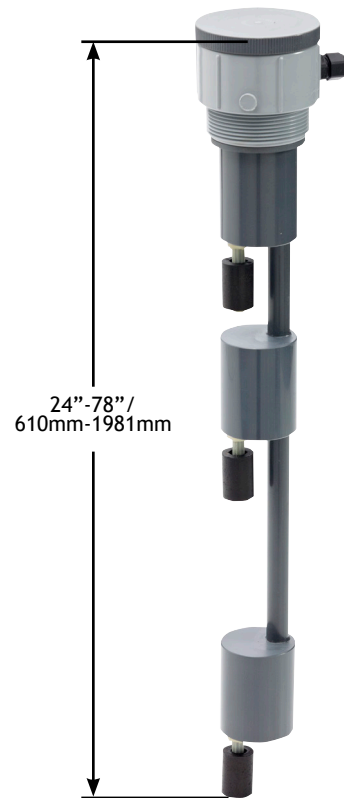

2325 Husky Way • Pacific, MO 63069
 (800) 325-3558 • Fax (636) 825-7300
www.husky.com • sales@husky.com

MADE IN THE U.S.A.