



KIT LUBE



PUMPS



METERS



NOZZLE METERS



NOZZLES



WASTE OIL EQUIPMENTS

K600 B/3

FEATURES

- EASY-TO-READ BIG DISPLAY
- SWIVEL DISPLAY
- STANDARD BATTERY
- PULSE-OUT VERSION AVAILABLE
- ADJUSTABLE FLANGES
- AA STANDARD BATTERY

The Piusi K600 B/3 is an oval gear meter suitable for monitoring the delivery of low, medium and high viscosity oils. This special version includes a large built-in digital display.

PERFORMANCE

up to
15.8 GPM
(60 L/min)

FLOW RATE

± 0.5 %

ACCURACY

less than
7.25 PSI

LOSS OF PRESSURE

0.2 %

REPEATABILITY



K600 B/3

K600 B/3 PULSE-OUT

PACKAGING

PART #	WEIGHT		PACKAGING			
	KG	LBS	MM	INCH	PCS/PALLET	PCS/BOX
METERS						
FOO491050	2	4.4	222X127X146	8.75X5X5.75	-	1
PULSERS						
FOO492030	2	4.4	222X127X146	8.75X5X5.75	-	1



FILTRATION



FLUID MONITORING



HOSE REELS



ACCESSORIES



MERCHANDISE



AIR



ANTIFREEZE



AdBlue®



BIODIESEL



DIESEL



FOOD



GASOLINE



GREASE



KEROSENE



OIL



WATER



WINDSCREEN

CHARTS

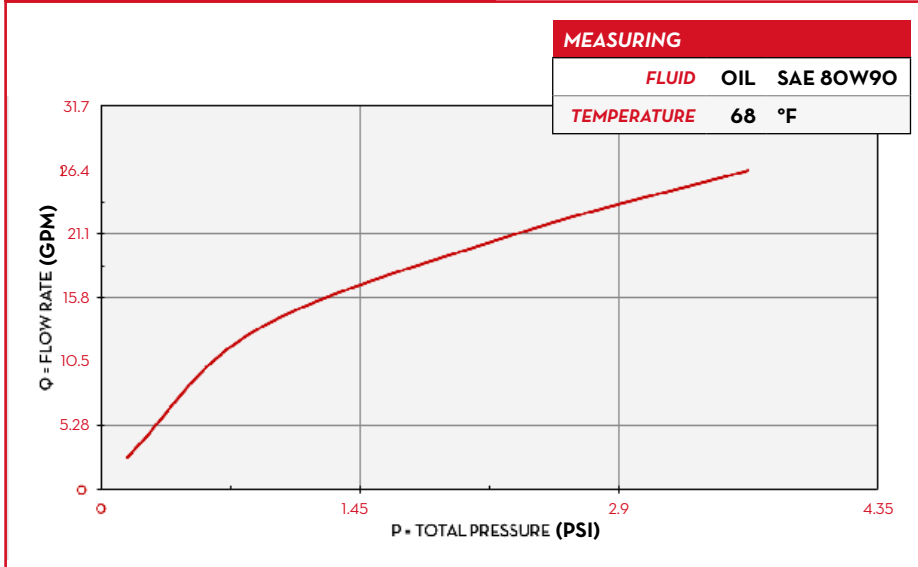

IN THE BOX

- K600 B/3 METER
- INSTRUCTION MANUAL

DETAILS



RESET BUTTON



OVAL GEAR



BIG DISPLAY

DIMENSIONS

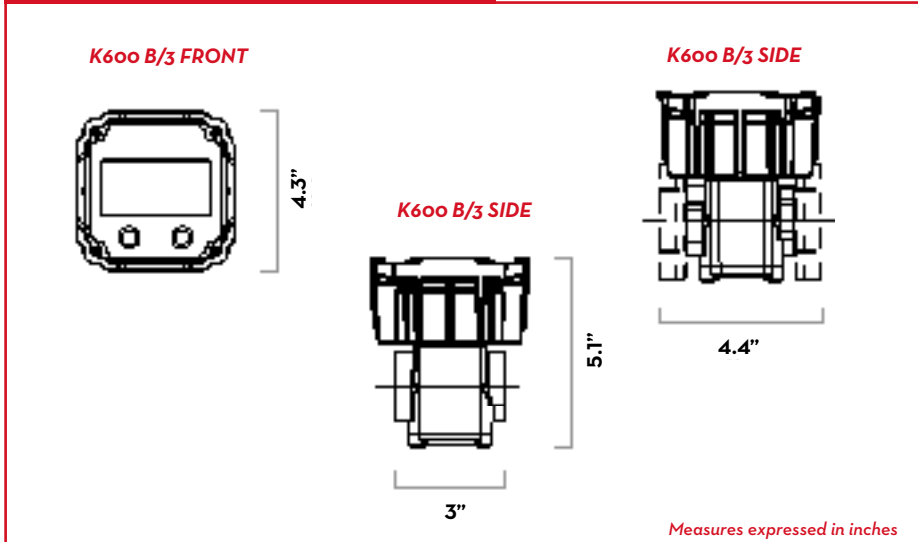

MATERIALS

- BODY: ALUMINUM
- GEARS: TECHNOPOLYMER

TECHNICAL DATA

PART #	DESCRIPTION	FLUIDS TYPE	FLOW RATE		PRESSURE		BATTERY INCLUDED NO. 2 2X1.5V	FLANGE	INLET OUTLET	INLET FILTER
			L/MIN	GPM	BAR	PSI				
METERS										
FOO491050	K600 B/3 OIL		6 - 60	1.58 - 15.8	70	1015	YES	YES	3/4" NPT	YES
PULSERS										
FOO492030	K600 B/3 PULSER OIL		6 - 60	1.58 - 15.8	70	1015	-	YES	3/4" NPT	YES

UPON REQUEST AVAILABLE IN NPTF VERSION AND DISPLAY IN GALLON/QUARTER OR PINT

K600 B/3