

DISPENSERS PIUSIBOX



EN. Quite often the hard environmental conditions can potentially threaten the refuelling operation of OTR equipment and vehicles. PIUSIBOX project is the solution to the need for refuelling quickly and safely in almost any setting.

An important tool for the reliability and longevity of your equipment.

Technical specifications:
A powerful and reliable self-priming transfer pump capable of delivering 12 GPM, complete with cables and switch, delivery hose, pump nozzle, and suction hose with foot valve.

ES. Muy a menudo las condiciones del medio ambiente afectan el proceso de dispensar gasolina en las maquinas o los vehículo. PIUSIBOX es la respuesta a esta necesidad, proveyendo un dispensador rápido que trabaja en prácticamente cualquier lugar y con seguridad.

Un equipo para el soporte, fiabilidad y larga vida de su equipo.

Características técnicas:
Potente y fiable bomba de dispensación auto cebante capaz de suministrar 45 l/min, incluye cables e interruptor.
Tubo de impulsión con pistola de suministro
Tubo de aspiración con válvula de pie

PT. Patentes internacionais que estão em curso de registo Com frequência, as condições ambientais adversas podem comprometer potencialmente a operação de reabastecimento das máquinas de terraplenagem e equipamentos. O projecto PIUSIBOX nasce da exigência de efectuar um reabastecimento rápido e seguro em qualquer lugar.

Um suporte importante para garantir a confiabilidade e a longa duração de seus equipamentos.

Especificações técnicas:
Uma bomba potente e confiável de descarga autodesparadora capaz de distribuir 45 l/min, completa com cabos e interruptor.
Tubo flexível de débito e pistola
Tubo flexível de aspiração com válvula de fundo

PERFORMANCE

- Flow rate up to 12 GPM
- 12-24 V DC operation
- Duty cycle 30 min.

- Caudal hasta 45 l/min
- Funcionamiento 12-24 V DC
- Ciclo de funcionamiento 30 min.

- Caudal até 45 l/min
- Funcionamento 12-24 V DC
- Ciclo de trabalho 30 min

DIMENSIONS

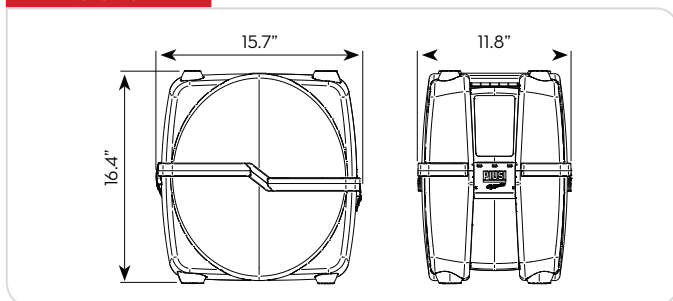

REGISTERED DESIGN

PATENT PENDING



PRODUCTS' RANGE WEIGHT AND PACKAGING

Part #	Weight		Packaging		
	kg	lbs	mm	inch	pcs/box
FOO23101	12	26.5	305x300x178	12x12x7	1
FOO23201	12	26.5	305x300x178	12x12x7	1

Flow rate

up to
12
GPM

2 YEAR
WARRANTY

PIUSI
USA®



PIUSIBOX PRO



ON REQUEST

K24 KIT

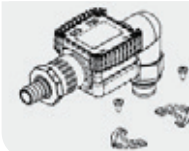

Part # R17256000
Assembly Kit for K24
PiusiBox

Cartridge



Part # FOO611000

FEATURES

Flexible hose



Hose length 20 ft
Hose interior ø 3/4"

Filter cartridge



Part # FOO611000

On/Off switch



Foot valve



Vantage model

Gloves



PRODUCTS' RANGE TECHNICAL DATA

Part #	Description	Fluids type	Flow rate		Voltage			Pump mod.	Duty cycle min.	Filter	Cartridge	Nozzle type	Flexible hose length	Foot valve mod. Vantage	Gloves
			l/min	gpm	AC V./Hz	DC Volt	Power Watt								
FOO23101	PIUSIBOX 12V PRO	D	43	12	12	260	22	BP 3000	30	YES	10 µm	Man.	20 ft	YES	YES
FOO23201	PIUSIBOX 24V PRO	D	43	12	24	310	13	BP 3000	30	YES	10 µm	Man.	20 ft	YES	YES