



1½ Hp Fixed Speed Submersible Turbine Pumps

Marketers concerned about fueling times, efficiency, serviceability, reliability and overall quality find it an easy choice to specify FE Petro™ brand submersible turbine pumps (STPs). An STP has to be reliable, it has to be safe, and it has to perform. That's why thousands of station owners around the world have trusted FE Petro™ STPs and the Franklin Electric motors that drive them to keep their business flowing for over 25 years. With best-in-class flow rates and backed by a long history of dependability FE Petro™ STPs simply do their job without fail, delivering fuel to customers day after day without a hitch.

Highlights

Active Air Eliminator

FE Petro™ brand STPs come standard with active air elimination, which eliminates air through the highest point in the pump head at all times when the pump is running, assuring air does not pass into discharge piping.

Safety and Ease of Maintenance

FE Petro™ brand STPs include a contractor electrical disconnect, which requires loosening only one bolt, allowing motor wiring to be disconnected without venting the dangerous tank vapors into the sump when servicing FE Petro™ submersible products.

Simple Servicing

If ever required, the pump can be easily removed from the tank by unthreading three bolts. There is no need to disconnect the syphon system or to remove the leak detector from the system to service the STP.

Manual Pressure Relief

As a standard FE Petro™ feature a vent screw is provided to bleed line pressure to zero when necessary. By turning this screw, product is diverted back to the tank, dropping line pressure to zero. This reduces fuel discharged into the sump manhole or dispenser pan during servicing, further protecting service technicians and the environment.

Reliable Check Valve

The STP uses the proven FE Petro™ line check valve. At 2 ¾" in diameter, this valve reduces pressure loss at high flow rates resulting in faster fueling times. FE Petro™ line check valves are offered in multiple configurations to best suit your line leak application.

Variable Length

The VL2 pump fits 94% of all known tank diameters and tank bury depth combinations. The VL1 and VL3 are available to handle installations shorter or longer than this range. The telescoping connection is a patented FE Petro feature. Pump length can be set by making one simple measurement and setting the pump length without affecting the UL listing.

Outlast, Outperform with Franklin Electric Inside

FE Petro™ STPs are powered by the legendary Franklin Electric motor and built for long term performance. Franklin Electric-powered submersible pumps provide maximum uptime and a proven track record in the fueling industry that spans more than four decades. They feature best-in-class flow rates and a long history of dependability.

Specifications

- 1½ Hp fixed speed models are available in variable length and fixed length options.
- Check valve: 2 ¼" diameter fluorocarbon seal constructed with cast aluminum body and steel backing washer.
- Pressure relief valve: available in four pressure relief settings, integral to check valve. Standard model relieves at 40 psi and resets above 35 psi.
- Syphon: venturi-type syphon primer supplied with every submersible. Syphon check valve and secondary syphon sold separately.
- Air eliminator: every submersible includes a tank return path with one-way check valve to provide active air elimination.
- Electrical disconnect: electrical yoke for positive contractor disconnect during service.

Pump Motor

- 1½ Hp fixed speed, 3450 rpm, multi-stage centrifugal type pump motor with integral, automatic, thermal overload protection.
- Standard pressure (150, two-stage) model, max. pressure = 34 psi.
- High pressure (H150, three-stage) model, max. pressure = 46 psi.

Approvals

- cULus listed.
- Consult factory for applicable approvals.

Performance

1½ Hp Fixed Speed Turbine Performance Chart

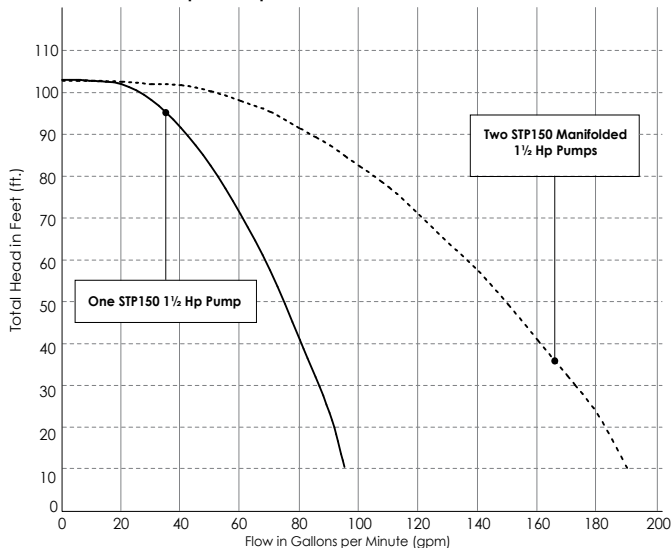

Note: Performance based on pumping solvent (0.78 specific gravity). Pressure is taken at the manifold discharge outlet. STP150 models are powered by a single-phase, 60 Hz, 208/230 Volt power supply.

Power Requirements

- 1½ Hp fixed speed models require single-phase, 208-230 VAC, 60 Hz incoming power.
- 1½ Hp fixed speed models incorporate a starting and running capacitor, with internal bleed resistor, rated 370 Volt, 15 microfarad.
- STP-SCI single-phase smart controllers and STP-CBS single-phase control boxes are available for 1½ Hp pump control.
- Max. motor draw: 11 Amps.

Liquid Compatibility

- Max. liquid viscosity: 70 SSU at 60 °F (15 °C).
- Standard STP models are UL and cUL listed for fuel mixtures containing up to 10% ethanol with gasoline, and 20% MTBE, 20% ETBE or 17% TAME with gasoline.
- STPAG (AG compatible) models are UL and cUL listed for fuel mixtures containing diesel fuel with up to 20% biodiesel, 100% biodiesel, up to 85% ethanol with gasoline, and 20% MTBE, 20% ETBE or 17% TAME with gasoline.
- 1½ Hp fixed speed models can also be used with diesel fuels, fuel oils, kerosene, Avgas and jet fuels in a non-gelled pourable state.
- All wetted elastomers are made of a high grade, fluorocarbon compound.

Quality Certification

- Franklin Fueling Systems is an ISO 9001 Certified Manufacturer.

1½ Hp High Pressure Fixed Speed Turbine Performance Chart

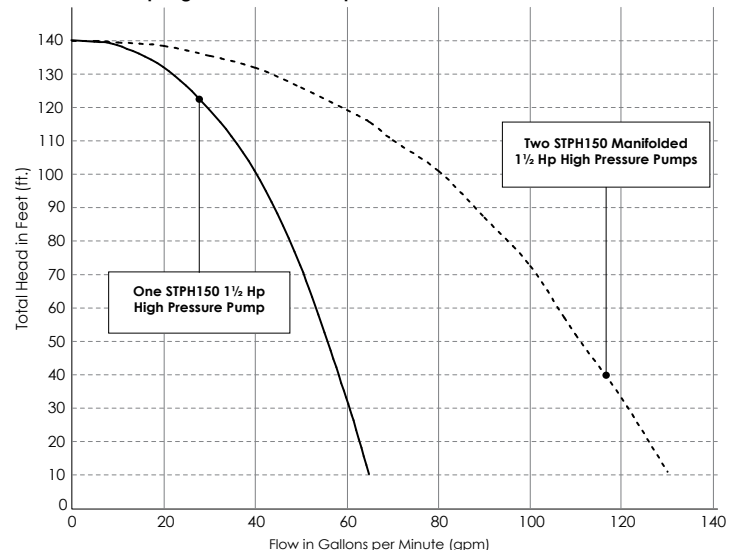

Note: Performance based on pumping solvent (0.78 specific gravity). Pressure is taken at the manifold discharge outlet. STPH150 models are powered by a single-phase, 60 Hz, 208/230 Volt power supply.

Ordering Information

A typical turbine model designation has up to five components to define the pump being supplied as follows:

STP XXXXX Y - A - B

STP = Basic Model Designation

XXXXX = Factory Installed Options (Model designations may include one or more of the following characters in alphabetical order.)

AG = Alcohol-gasoline compatible (up to E85, up to B20, and B100)
(Note standard models up to 10% ethanol capable)

F = Floating suction adapter (1½" NPT female adapter)

K = Intake filter screen (IFS, factory installed to PMA)

M = MagShell™ (flow enhancing, expanded PMA shell)

*R = Model R check valve (24 psi relief/22 psi reset for PLLD)

*W = Model W check valve (16 psi relief/13 psi reset for PPM4000)

Y = Pump Motor Horsepower Rating

150 = 1½ Hp fixed speed

A = Model Length (see table)

VL1 = Variable length range #1.

VL2 = Variable length range #2.

VL3 = Variable length range #3.

(Note VL2 models fit 94% of all known installations)

B = Riser Pipe Length (see diagram)

Riser pipe length is expressed as two numeric characters that indicate the total length of the riser in inches. Riser pipes are available from 7" to 69" in 1" increments (additional charge for risers 31" or longer).

Notes:

*If not otherwise specified, all STP models are supplied with standard model check valve (40 psi relief /35 psi reset for MLD, TS-LS300, and TS-LS500).

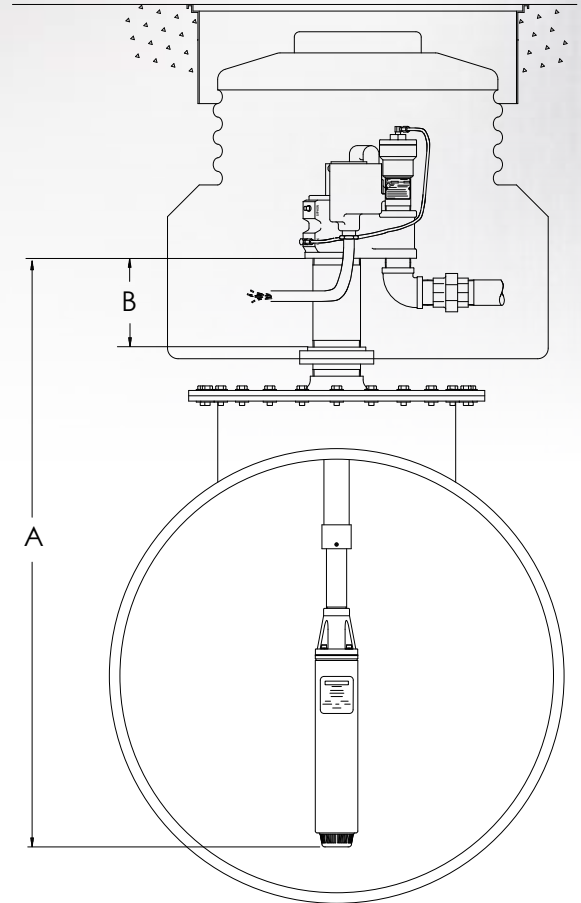

Model Length (A)

STP Horsepower	Model Length Range	Model Length Designation
2 Hp	60" - 88"	VL1
	91" - 152"	VL2
	123" - 214"	VL3
2 Hp high pressure	61" - 89"	VL1
	92" - 152"	VL2
	124" - 215"	VL3

Ordering Information continued

Standard 1½ Hp Fixed Speed Submersible Turbine Pumps

Model	Description	Model Length Range Number	Model Length Range*
STP150-VL1	1½ Hp fixed speed	VL1	60"-88"
STP150-VL2	1½ Hp fixed speed	VL2	91"-152"
STP150-VL3	1½ Hp fixed speed	VL3	123"-214"
STPH150-VL1	1½ Hp high pressure fixed speed	VL1	61"-89"
STPH150-VL2	1½ Hp high pressure fixed speed	VL2	92"-152"
STPH150-VL3	1½ Hp high pressure fixed speed	VL3	124"-215"

Alcohol-Gas (AG) 1½ Hp Fixed Speed Submersible Turbine Pumps

Model	Description	Model Length Range Number	Model Length Range*
STPAG150-VL1	1½ Hp AG fixed speed	VL1	60"-88"
STPAG150-VL2	1½ Hp AG fixed speed	VL2	91"-152"
STPAG150-VL3	1½ Hp AG fixed speed	VL3	123"-214"
STPAGH150-VL1	1½ Hp AG high pressure fixed speed	VL1	61"-89"
STPAGH150-VL2	1½ Hp AG high pressure fixed speed	VL2	92"-152"
STPAGH150-VL3	1½ Hp AG high pressure fixed speed	VL3	124"-215"

Notes:

1. STP models are compatible with fuel mixtures containing up to 10% ethanol with gasoline, diesel fuels, and 20% MTBE, 20% ETBE or 17% TAME with gasoline. STPAG models are compatible with fuel mixtures containing diesel fuel with up to 20% biodiesel, 100% biodiesel, up to 85% ethanol with gasoline, and 20% MTBE, 20% ETBE or 17% TAME with gasoline.
2. All models are supplied with a standard check valve unless factory option "R" or "W" is specified.
3. All above models require single-phase, 208-230 VAC, 60 Hz incoming power.
4. 4" riser pipe, if supplied locally, must be 4½" OD by 3/16" WT tubing.
5. For riser pipe lengths 31" to 69", additional charges apply.

*Model length (A) defined as the dimension from turbine manifold bottom to pump motor inlet.

Factory Installed Options

Specified in model number at time of STP order.

Model	Description
F	Floating suction adapter, 1½" NPT female, must be factory installed
K	IFS (intake filter screen) factory assembled to pump motor assembly
R	Model R check valve, factory installed, for Veeder-Root™ PLLD Line Leak
W	Model W check valve, factory installed, for Red Jacket PPM4000 Line Leak

Ordering Information continued

Field Installed Options

1½ Hp fixed speed specific accessories.

Model	Description
400137908	Syphon check valve, alcohol-gasoline compatible (when ordered with STP)
400818921	STP-CBS, single-phase control box with lockout switch, 110 Volt coil
402312921	STP-DHI-SCI, combo DHI with factory wired STP-SCI (when purchased with a 4" STP)*
402312921	STP-DHI-SCI, combo DHI with factory wired STP-SCI (when purchased without a 4" STP)
402313921	STP-DHI-CBS, combo DHI with factory wired STP-CBS
402459931	Model 65 psi check valve (for slave of manifolded STPs with Veeder-Root™ PLLD)
402507930	Secondary syphon kit (when two syphon primes are required for one STP)
5800100215	STP-SCI, single-phase smart controller (when purchased without a 4" STP)
5800100215	STP-SCI, single-phase smart controller (when purchased with a 4" STP)*
5800300100	STP-DHI, dispenser hook isolation for 110 Volt dispenser handle switches, up to eight each

*When purchasing STP-SCI or STP-DHI-SCI in equal quantities of fixed speed 4" STPs, the STP-SCI or STP-DHI-SCI will be invoiced at special discount pricing.

FE PETRO®

A Franklin Fueling Systems Brand

franklinfueling.com

3760 Marsh Rd. • Madison, WI 53718, USA

Tel: +1 608 838 8786 • Fax: +1 608 838 6433

Tel: USA & Canada +1 800 225 9787 • Tel: UK +44 (0)1473 243300

Tel: Mex 001 800 738 7610 • Tel: FR +33 (0)1 69 21 41 41 • Tel: CH +86 10 8565 4566

